

Space-saving design light short tie rod hydraulic cylinders for 16 MPa

- Compact double acting hydraulic cylinders for 16 MPa having bores of 32 to 160 mm.
- The cylinders are interchangeable with a part of 160S-1 Series 16 MPa compact design cylinders. They are as space-saving as and lighter than the compact design cylinders.
- ST style cylinders with large bores of 100 to 160 mm (not included in 160S-1 Series) are available. Light, compact and space-saving design, and remarkably reduced production leadtime.



Standard Specifications

Type	Standard type, Switch Set
Nominal pressure	16 MPa
Maximum allowable pressure	16 MPa
Proof test pressure	24 MPa
Minimum operating pressure	0.3 MPa or less
Working speed range	8 to 100mm/s
Working temperature range (ambient temperature)	Standard type -10 to +120°C Switch Set AX/AZ type -10 to +70°C (No freezing)
Structure of cushioning	None
Applicable fluid	Petroleum-based fluid (When using another fluid, refer to the table of fluid adaptability.)
Tolerance for thread	JIS 6g/6H
Tolerance of stroke	0 to 0.8mm
Tube material	Standard type ● Carbon steel for machine structural use Switch Set ● Stainless steel
Mounting style	SA, SB, EA, EB, FA, FB, LD
Seal material	6 HNBR
Rod end thread	Male thread

Adaptability of Fluid to Seal Material

Seal material	Applicable fluid				
	Petroleum-based fluid	Water-glycol fluid	Phosphate ester fluid	Water in oil fluid	Oil in water fluid
6 HNBR	○	○	×	○	○

Terminologies

Nominal pressure

Pressure given to a cylinder for convenience of naming. It is not always the same as the working pressure (rated pressure) that guarantees performance under the specified conditions.

Maximum allowable pressure
Maximum allowable pressure generated in a cylinder (surge pressure, etc.).

Proof test pressure

Test pressure against which a cylinder can withstand without unreliable performance at the return to nominal pressure.

Minimum operating pressure
Minimum pressure at which cylinder installed horizontally operates under no load.

- Notes) ● The hydraulic pressure generated in a cylinder due to the inertia of load must be lower than the maximum allowable pressure.
● This series of cylinders does not have air vents.
● Since side load (eccentric load) must not be applied to the piston rod, take care when installing the cylinder.

Product Lineup

Unit: mm

Series Variation	Type	Mounting Style	φ32	φ40	φ50	φ63	φ80	φ100	φ125	φ140	φ160		
General purpose type	Double acting single rod	Standard type 160ST-1	SA	●	●	●	●	●	●	●	●	●	
			SB	●	●	●	●	●	●	●	●	●	●
			EA	●	●	●	●	●	●	●	●	●	●
			EB	●	●	●	●	●	●	●	●	●	●
			FA	●	●	●	●	●	●	●	●	●	●
			FB	●	●	●	●	●	●	●	●	●	●
			LD	●	●	●	●	●	●	●	●	●	●
			SA	●	●	●	●	●	●	●	●	●	●
	SB	●	●	●	●	●	●	●	●	●	●	●	
	EA	●	●	●	●	●	●	●	●	●	●	●	
	EB	●	●	●	●	●	●	●	●	●	●	●	
	FA	●	●	●	●	●	●	●	●	●	●	●	
	FB	●	●	●	●	●	●	●	●	●	●	●	
	LD	●	●	●	●	●	●	●	●	●	●	●	

- Notes) ● When using a sensor, use a Switch Set Cylinder.
● No sensor can be mounted onto the standard type cylinder.

Double acting single rod



Standard type (160ST-1)



Switch Set (160ST-1R)

Stroke Range

Unit: mm

Bore	SA/SB style		EA/EB style		FA/FB/LD style	
	Stroke		Stroke		Stroke	
	1 to 100	101 to 300	1 to 100	101 to 300	1 to 100	101 to 300
φ 32	□	○	□	○	□	○
φ 40	□	○	□	○	□	○
φ 50	□	○	□	○	□	○
φ 63	□	○	□	○	□	○
φ 80	□	○	□	○	□	○
φ 100	□	○	□	○		
φ 125	□	○	□	○		
φ 140	○	○	○	○		
φ 160	○	○	○	○		

Note) The appearance varies depending on the bore and mounting style. ○: Standard range □: Semi-standard range

How to order

General Purpose Type

● Standard type

160ST-1

● Switch Set

160ST-1R

Standard type
 160ST-1 : Double acting single rod
 Switch Set
 160ST-1R: Double acting single rod

[6] HNBR

- [SA] Rod tapped hole type
- [SB] Cap tapped hole type
- [EA] Rod through hole type
- [EB] Cap through hole type
- [FA] Rod flange
- [FB] Cap flange
- [LD] Foot type

SA-SB-EA-EB: ϕ 32 to ϕ 160
 FA-FB-LD : ϕ 32 to ϕ 80

- * Male threaded rod end is standard.
- * When using the lock nut, specify the rod screw length according to the screw fitting length. For the recommended size, see the "Lock Nut" page.
- * For the shape of rod end such as female threaded rod end, consult us.
- * For the G thread port and air vent types, consult us.

Modification of port position

The standard port position is (A). When modifying the position, enter the symbol shown in the dimensional drawing.

Example) 160ST-1 6SA63N200 - [A] 0 L
 Port position(A, B, C, D) | No cushion

Note) For ϕ 40 FB style cylinders, the port position B or D cannot be selected.

Mounting Style

- [SA] Rod side tapped hole type
- [SB] Cap side tapped hole type
- [EA] Rod side through hole type
- [EB] Cap side through hole type

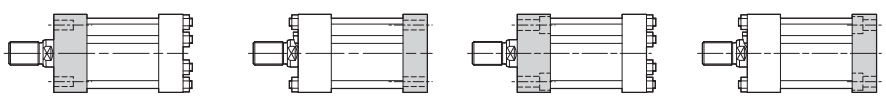

- [FA] Rod rectangular flange
- [FB] Cap rectangular flange
- [LD] Foot type (side lugs)

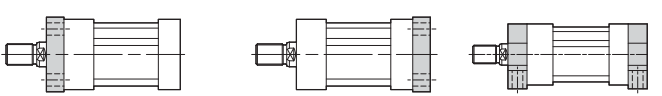

Short Tie Rod Hydraulic Cylinder

160ST-1

Sensor List

Type	Sensor symbol	Load voltage range	Load current range	Max. switching capacity	Protective circuit	Indicating lamp	Wiring method	Cord length	Applicable load											
Reed sensor	[AF] AX101CE	DC:5 to 30V AC:5 to 120V	DC:5 to 40mA AC:5 to 20mA	DC:1.5W AC:2VA	None	LED (lights in red when sensing)	0.3 mm ² , 2-core, outer dia. ϕ 4 mm, rear wiring	1.5m	Small relay programmable controller											
	[AG] AX105CE							5m												
	[AH] AX111CE							1.5m												
	[AJ] AX115CE	5m																		
	[AE] AX125CE	DC:30V or less AC:120V or less	DC:40mA or less AD:20mA or less	DC:1.5W AC:2VA	None	None	5m													
	[AK] AX11ACE	AC:5 to 120V	5 to 20mA				2VA	Provided		LED (lights in red when sensing)	4-pin connector type, rear wiring	0.5m								
	[AL] AX11BCE	DC:5 to 30V	5 to 40mA				1.5W	Provided		LED (lights in red when sensing)	4-pin connector type, rear wiring	0.5m								
	[AP] AZ101CE	DC:5 to 30V AC:5 to 120V	DC:5 to 40mA AC:5 to 20mA	DC:1.5W AC:2VA	None	LED (lights in red when sensing)	0.3 mm ² , 2-core, outer dia. ϕ 4 mm, upper wiring	1.5m												
	[AR] AZ105CE							5m												
	[AS] AZ111CE							1.5m												
	[AT] AZ115CE	5m																		
	[AN] AZ125CE	DC:30V or less AC:120V or less	DC:40mA or less AD:20mA or less	DC:1.5W AC:2VA	None	None	5m													
	[AU] AZ11ACE	AC:5 to 120V	5 to 20mA				2VA	Provided		LED (lights in red when sensing)	4-pin connector type, upper wiring	0.5m								
	[AV] AZ11BCE	DC:5 to 30V	5 to 40mA				1.5W	Provided		LED (lights in red when sensing)	4-pin connector type, upper wiring	0.5m								
	[AM] AX135CE	AC/DC:90 to 240V	5 to 300mA	B contact output	Provided	LED (lights in red when not sensing)	0.3 mm ² , 2-core, outer dia. ϕ 4 mm, rear wiring 0.3 mm ² , 2-core, outer dia. ϕ 4 mm, upper wiring	5m												
[AY] AZ135CE	5m																			
[BE] AX201CE-1	DC:5 to 30V							5 to 40mA	-	Provided	LED (lights in red when sensing)	0.3 mm ² , 2-core, outer dia. ϕ 4 mm, rear wiring	1.5m							
[BF] AX205CE-1													5m							
[CE] AX211CE-1													1.5m							
[CF] AX215CE-1													5m							
[CH] AX21CCE-1													4-pin connector type, rear wiring	0.5m						
[CJ] AX21DCE-1													1m							
[BM] AZ201CE-1													DC:5 to 30V	5 to 40mA	-	Provided	LED (lights in red when sensing)	0.3 mm ² , 2-core, outer dia. ϕ 4 mm, upper wiring	1.5m	
[BN] AZ205CE-1																			5m	
[CM] AZ211CE-1																			1.5m	
[CN] AZ215CE-1																			5m	
[CT] AX211CE-1																			0.3 mm ² , 2-core, outer dia. ϕ 4 mm, rear wiring	1.5m
[CU] AX215CE-1																			5m	
[CV] AX21BCE-1																			4-pin connector type, rear wiring	0.5m
[CW] AZ211CE-1		DC:5 to 30V	5 to 40mA	-	Provided	LED (two-LED type in red/green)	0.3 mm ² , 2-core, outer dia. ϕ 4 mm, upper wiring												1.5m	
[CX] AZ215CE-1																			5m	
[CY] AZ21BCE-1	4-pin connector type, upper wiring							0.5m												

- Notes) ● For the sensors without a protective circuit, be sure to provide a protective circuit (SK-100) with the load when using any induction load (relay, etc.).
 ● The output logic of AX and AZ135CE is B contact. When the piston is detected, the sensor contact turns off (the lamp turns on).
 ● We recommend AND Unit (AU series) for multiple sensors connected in series.

● Standard type

AX type (rear wiring) AZ type (upper wiring)



Short Tie Rod Hydraulic Cylinder

160ST-1

SA/Rod side tapped hole type

160ST-1 6 SA [Bore] N [Stroke] - [A] 0

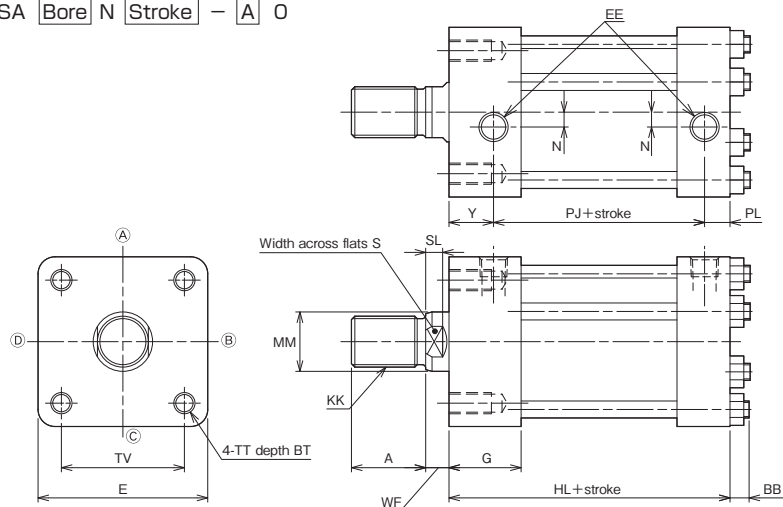

- * The number and positions of tie rods vary depending on the bore.
- * Since side load (eccentric load) must not be applied to the piston rod, take care when installing the cylinder.

Dimensional Table(SA/Rod side tapped hole type)

Symbol Bore	A	BB	BT	E	EE	G	HL		KK	MM	N
							Standard type	Switch Set			
φ32	25	0	15	□62	Rc1/4	34	81.5	88	M16×1.5	φ18	0
φ40	30	0	20	□70	Rc1/4	34	81.5	99	M20×1.5	φ22	7
φ50	35	0	34	□80	Rc1/4	34	82.5	98	M24×1.5	φ28	7
φ63	45	0	34	□94	Rc1/4	34	86	100	M30×1.5	φ36	0
φ80	60	0	39	□114	Rc3/8	39	101	118	M39×1.5	φ45	0
φ100	75	13	39	□140	Rc3/8	39	112	120	M48×1.5	φ56	0
φ125	95	14	39	□172	Rc1/2	39	121	135	M64×2	φ70	0
φ140	110	16	49	□196	Rc1/2	49	152	152	M72×2	φ80	0
φ160	120	18	49	□235	Rc1/2	49	159	159	M80×2	φ90	0

Symbol Bore	PJ		PL	S	SL	TT	TV	WF	Y
	Standard type	Switch Set							
φ32	47.5	54	12	14	7	M6×1	□47	10	22
φ40	47.5	65	12	19	7	M8×1.25	□52	10	22
φ50	49.5	65	12	24	8	M10×1.5	□58	11	21
φ63	54	68	12	30	9	M12×1.75	□69	13	20
φ80	64	81	15	41	14	M16×2	□86	17	22
φ100	75	83	15	50	22	M18×2.5	□106	26	22
φ125	81	95	20	65	25	M22×2.5	□132	30	20
φ140	105	105	20	75	31	M24×3	□150	35	27
φ160	109	109	23	85	33	M27×3	□175	40	27

SB/Cap side tapped hole type

160ST-1 6 SB [Bore] N [Stroke] - [A] 0

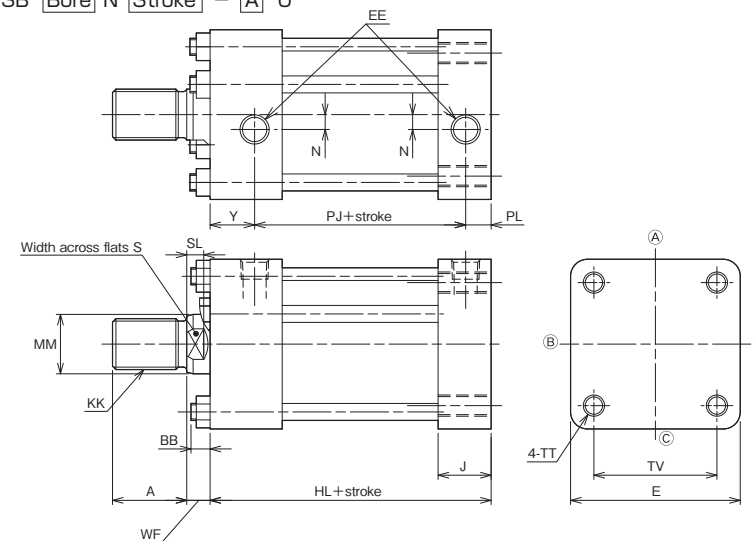

- * The number and positions of tie rods vary depending on the bore.
- * Since side load (eccentric load) must not be applied to the piston rod, take care when installing the cylinder.

Dimensional Table(SB/Cap side tapped hole type)

Symbol Bore	A	BB	E	EE	HL		J	KK	MM	N
					Standard type	Switch Set				
φ32	25	0	□62	Rc1/4	81.5	88	25	M16×1.5	φ18	0
φ40	30	0	□70	Rc1/4	81.5	99	25	M20×1.5	φ22	7
φ50	35	0	□80	Rc1/4	82.5	98	25	M24×1.5	φ28	7
φ63	45	0	□94	Rc1/4	86	100	25	M30×1.5	φ36	0
φ80	60	0	□114	Rc3/8	101	118	33	M39×1.5	φ45	0
φ100	75	13	□140	Rc3/8	112	120	33	M48×1.5	φ56	0
φ125	95	14	□172	Rc1/2	121	135	40	M64×2	φ70	0
φ140	110	16	□196	Rc1/2	152	152	40	M72×2	φ80	0
φ160	120	18	□235	Rc1/2	159	159	45	M80×2	φ90	0

Symbol Bore	PJ		PL	S	SL	TT	TV	WF	Y
	Standard type	Switch Set							
φ32	47.5	54	12	14	7	M6×1	□47	10	22
φ40	47.5	65	12	19	7	M8×1.25	□52	10	22
φ50	49.5	65	12	24	8	M10×1.5	□58	11	21
φ63	54	68	12	30	9	M12×1.75	□69	13	20
φ80	64	81	15	41	14	M16×2	□86	17	22
φ100	75	83	15	50	22	M18×2.5	□106	26	22
φ125	81	95	20	65	25	M22×2.5	□132	30	20
φ140	105	105	20	75	31	M24×3	□150	35	27
φ160	109	109	23	85	33	M27×3	□175	40	27

EA/Rod side through hole type

160ST-1 6 EA Bore N Stroke - A 0

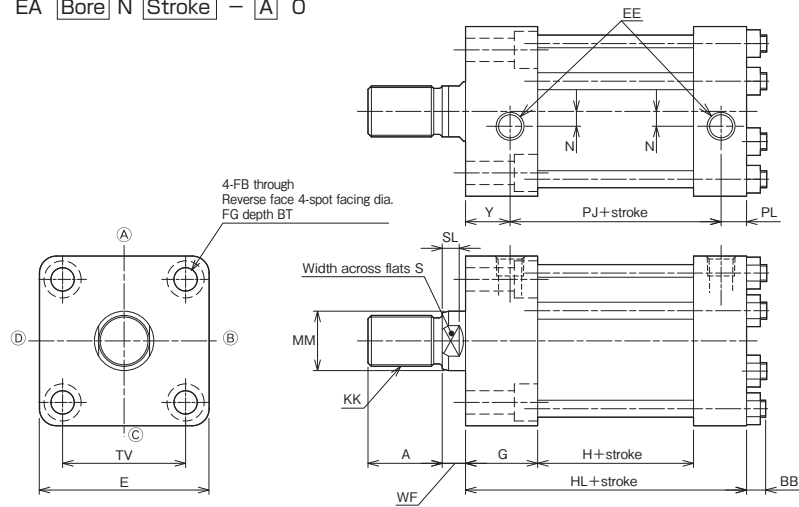

- * The number and positions of tie rods vary depending on the bore.
- * The cap covers of 140 and 160 mm bore cylinders have holes for mounting bolts.
- * Since side load (eccentric load) must not be applied to the piston rod, take care when installing the cylinder.

Dimensional Table(EA/Rod side through hole type)

Symbol Bore	A	BB	BT	E	EE	FB	FG	G	H		HL	
									Standard type	Switch Set	Standard type	Switch Set
φ32	25	0	6.5	□62	Rc1/4	6.6	11	34	22.5	29	81.5	88
φ40	30	0	8.6	□70	Rc1/4	9	14	34	22.5	40	81.5	99
φ50	35	0	10.8	□80	Rc1/4	11	17.5	34	23.5	39	82.5	98
φ63	45	0	13	□94	Rc1/4	14	20	34	27	41	86	100
φ80	60	0	15.2	□114	Rc3/8	16	23	39	29	46	101	118
φ100	75	13	19.5	□140	Rc3/8	20	29	39	40	48	112	120
φ125	95	14	23.5	□172	Rc1/2	24	35	39	42	56	121	135
φ140	110	16	25.5	□196	Rc1/2	26	39	49	63	63	152	152
φ160	120	18	29	□235	Rc1/2	30	43	49	65	65	159	159

Symbol Bore	KK	MM	N	PJ		PL	S	SL	TV	WF	Y
				Standard type	Switch Set						
φ32	M16×1.5	φ18	0	47.5	54	12	14	7	□47	10	22
φ40	M20×1.5	φ22	7	47.5	65	12	19	7	□52	10	22
φ50	M24×1.5	φ28	7	49.5	65	12	24	8	□58	11	21
φ63	M30×1.5	φ36	0	54	68	12	30	9	□69	13	20
φ80	M39×1.5	φ45	0	64	81	15	41	14	□86	17	22
φ100	M48×1.5	φ56	0	75	83	15	50	22	□106	26	22
φ125	M64×2	φ70	0	81	95	20	65	25	□132	30	20
φ140	M72×2	φ80	0	105	105	20	75	31	□150	35	27
φ160	M80×2	φ90	0	109	109	23	85	33	□175	40	27

EB/Cap side through hole type

160ST-1 6 EB Bore N Stroke - A 0

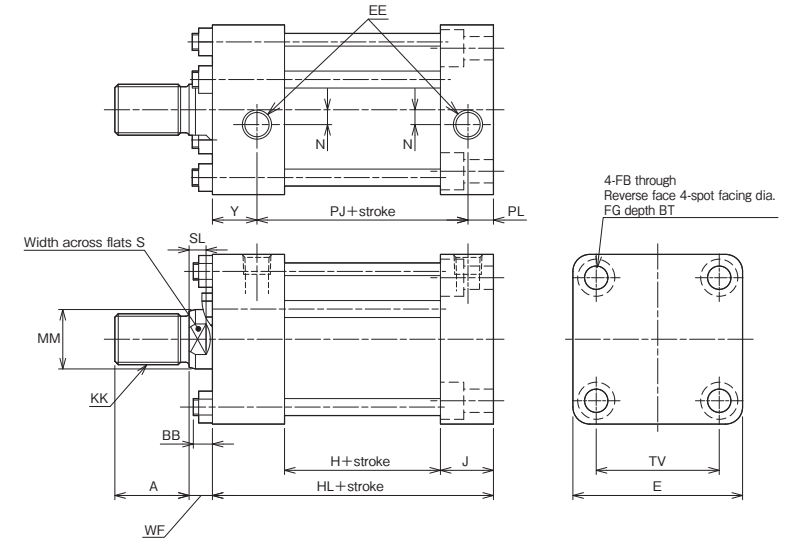

- * The number and positions of tie rods vary depending on the bore.
- * The cap covers of 140 and 160 mm bore cylinders have holes for mounting bolts.
- * Since side load (eccentric load) must not be applied to the piston rod, take care when installing the cylinder.

Dimensional Table(EB/Cap side through hole type)

Symbol Bore	A	BB	BT	E	EE	FB	FG	J	H		HL	
									Standard type	Switch Set	Standard type	Switch Set
φ32	25	0	6.5	□62	Rc1/4	6.6	11	25	22.5	29	81.5	88
φ40	30	0	8.6	□70	Rc1/4	9	14	25	22.5	40	81.5	99
φ50	35	0	10.8	□80	Rc1/4	11	17.5	25	23.5	39	82.5	98
φ63	45	0	13	□94	Rc1/4	14	20	25	27	41	86	100
φ80	60	0	15.2	□114	Rc3/8	16	23	33	29	46	101	118
φ100	75	13	19.5	□140	Rc3/8	20	29	33	40	48	112	120
φ125	95	14	23.5	□172	Rc1/2	24	35	40	42	56	121	135
φ140	110	16	25.5	□196	Rc1/2	26	39	40	63	63	152	152
φ160	120	18	29	□235	Rc1/2	30	43	45	65	65	159	159

Symbol Bore	KK	MM	N	PJ		PL	S	SL	TV	WF	Y
				Standard type	Switch Set						
φ32	M16×1.5	φ18	0	47.5	54	12	14	7	□47	10	22
φ40	M20×1.5	φ22	7	47.5	65	12	19	7	□52	10	22
φ50	M24×1.5	φ28	7	49.5	65	12	24	8	□58	11	21
φ63	M30×1.5	φ36	0	54	68	12	30	9	□69	13	20
φ80	M39×1.5	φ45	0	64	81	15	41	14	□86	17	22
φ100	M48×1.5	φ56	0	75	83	15	50	22	□106	26	22
φ125	M64×2	φ70	0	81	95	20	65	25	□132	30	20
φ140	M72×2	φ80	0	105	105	20	75	31	□150	35	27
φ160	M80×2	φ90	0	109	109	23	85	33	□175	40	27

FA/Rod rectangular flange

160ST-1 6 FA Bore N Stroke - A 0

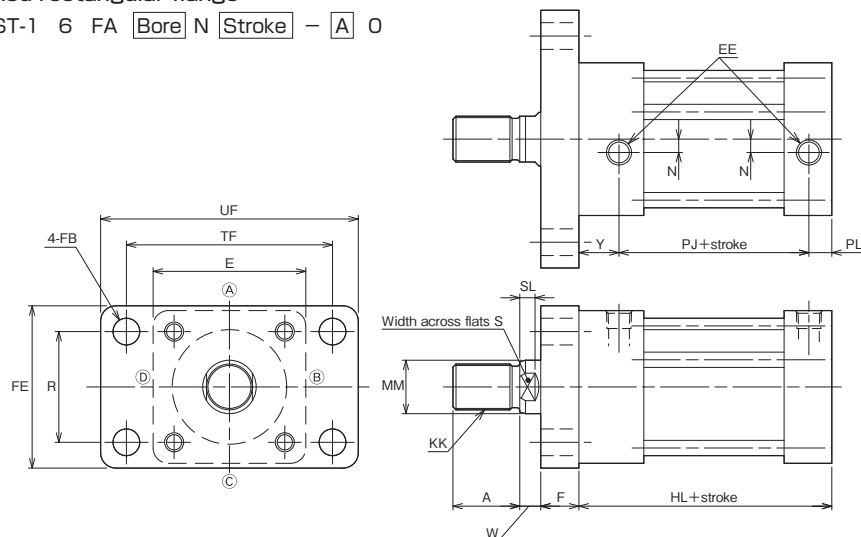

- * The number and positions of tie rods vary depending on the bore.
- * Since side load (eccentric load) must not be applied to the piston rod, take care when installing the cylinder.

Dimensional Table(FA/Rod rectangular flange)

Symbol Bore	A	E	EE	F	FB	FE	HL		KK	MM	N
							Standard type	Switch Set			
φ32	25	□62	Rc1/4	15	φ 6.6	62	81.5	88	M16×1.5	φ18	0
φ40	30	□70	Rc1/4	20	φ 11	70	81.5	99	M20×1.5	φ22	7
φ50	35	□80	Rc1/4	20	φ 14	85	82.5	98	M24×1.5	φ28	7
φ63	45	□94	Rc1/4	20	φ 14	98	86	100	M30×1.5	φ36	0
φ80	60	□114	Rc3/8	25	φ 18	118	101	118	M39×1.5	φ45	0

Symbol Bore	PJ		PL	R	S	SL	TF	UF	W	Y
	Standard type	Switch Set								
φ32	47.5	54	12	40	14	7	80	95	10	22
φ40	47.5	65	12	46	19	7	96	118	10	22
φ50	49.5	65	12	58	24	8	108	135	11	21
φ63	54	68	12	65	30	9	124	150	13	20
φ80	64	81	15	87	41	14	154	185	17	22

FB/Cap rectangular flange

160ST-1 6 FB Bore N Stroke - A 0

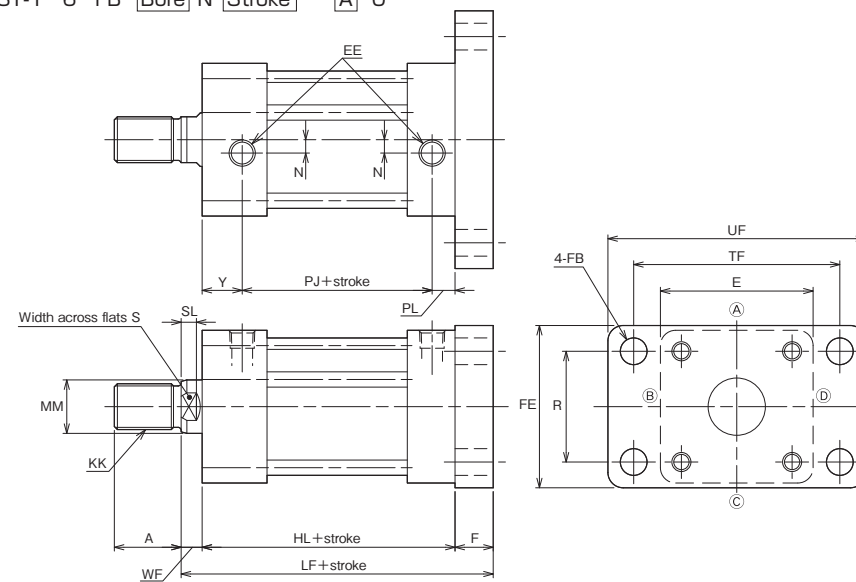

- * The number and positions of tie rods vary depending on the bore.
- * Since side load (eccentric load) must not be applied to the piston rod, take care when installing the cylinder.

Dimensional Table(FB/Cap rectangular flange)

Symbol Bore	A	E	EE	F	FB	FE	HL		KK	LF	
							Standard type	Switch Set		Standard type	Switch Set
φ32	25	□62	Rc1/4	15	φ 6.6	62	81.5	88	M16×1.5	106.5	113
φ40	30	□70	Rc1/4	20	φ 11	70	81.5	99	M20×1.5	111.5	129
φ50	35	□80	Rc1/4	20	φ 14	85	82.5	98	M24×1.5	113.5	129
φ63	45	□94	Rc1/4	20	φ 14	98	86	100	M30×1.5	119	133
φ80	60	□114	Rc3/8	25	φ 18	118	101	118	M39×1.5	143	160

Symbol Bore	MM	N	PJ		PL	R	S	SL	TF	UF	WF	Y
			Standard type	Switch Set								
φ32	φ18	0	47.5	54	12	40	14	7	80	95	10	22
φ40	φ22	7	47.5	65	12	46	19	7	96	118	10	22
φ50	φ28	7	49.5	65	12	58	24	8	108	135	11	21
φ63	φ36	0	54	68	12	65	30	9	124	150	13	20
φ80	φ45	0	64	81	15	87	41	14	154	185	17	22

LD/Foot type

160ST-1 6 LD [Bore] N [Stroke] - [A] 0

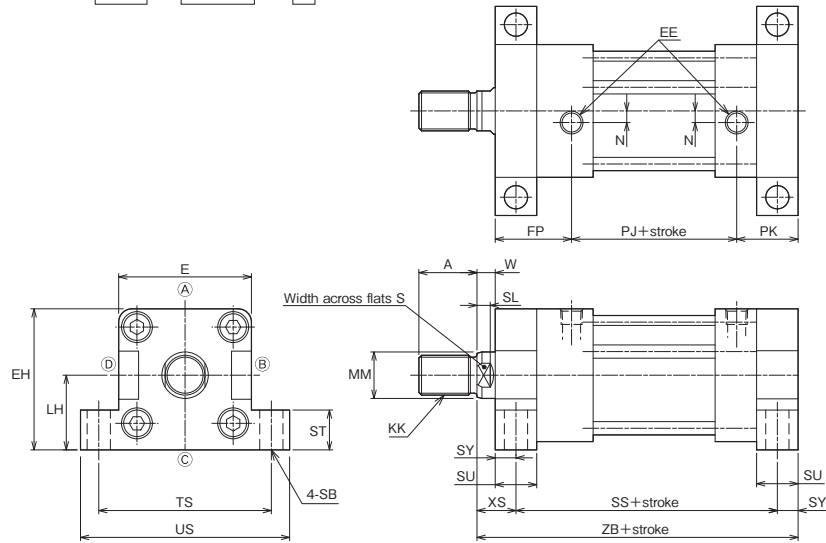

* The number and positions of tie rods vary depending on the bore.
 * Since side load (eccentric load) must not be applied to the piston rod, take care when installing the cylinder.

Dimensional Table(LD/Foot type)

Symbol Bore	A	E	EE	EH	FP	KK	LH	MM	N	PJ	
										Standard type	Switch Set
φ32	25	□62	Rc1/4	66	42	M16×1.5	35	φ18	0	47.5	54
φ40	30	□70	Rc1/4	72.5	42	M20×1.5	37.5	φ22	7	47.5	65
φ50	35	□80	Rc1/4	85	46	M24×1.5	45	φ28	7	49.5	65
φ63	45	□94	Rc1/4	97	45	M30×1.5	50	φ36	0	54	68
φ80	60	□114	Rc3/8	117	52	M39×1.5	60	φ45	0	64	81

Symbol Bore	PK	S	SB	SL	SS		ST	SU	SY	TS	US	W
					Standard type	Switch Set						
φ32	32	14	9	7	101.5	108	16	20	10	79	94	10
φ40	32	19	11	7	101.5	119	20	20	10	90	108	10
φ50	37	24	14	8	107.5	123	24	25	12.5	104	126	11
φ63	37	30	16	9	111	125	30	25	12.5	121	146	13
φ80	45	41	18	14	131	148	35	30	15	144	172	17

Symbol Bore	XS	ZB	
		Standard type	Switch Set
φ32	20	131.5	138
φ40	20	131.5	149
φ50	23.5	143.5	159
φ63	25.5	149	163
φ80	32	178	195

Switch Set

160ST-1R 6 SA [Bore] N [Stroke] - [A] 0 [Sensor symbol] [Sensor quantity]

AX/AZ type (reed sensor/solid state sensor)

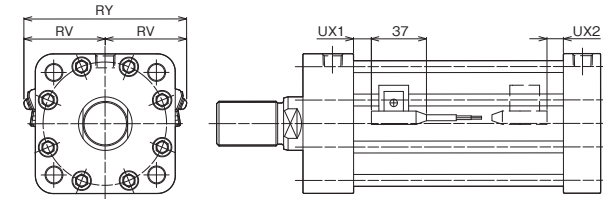

* The number and positions of tie rods vary depending on the bore.
 * Since side load (eccentric load) must not be applied to the piston rod, take care when installing the cylinder.

Dimensional Table/Switch Set

Symbol Bore	RV	RY	UX1	UX2
φ32	34	68	5	4
φ40	44	88	12	11
φ50	50	100	11	10
φ63	55	110	12	11
φ80	64	128	14	13
φ100	75	150	15	14
φ125	89	178	20	19
φ140	99	198	22	21
φ160	115	230	23	22

Operating Range and Hysteresis

Symbol Bore	Reed sensor		Solid state sensor	
	AX1**		AX2**	
	Operating range	Hysteresis	Operating range	Hysteresis
φ32	4 to 14	2 or less	3 to 8	1 or less
φ40				
φ50				
φ63				
φ80				
φ100	11 to 18	4 to 10	6 to 13	
φ125	5 to 15			
φ140	11 to 20	6 to 13	6 to 13	
φ160				

Lock Nut

The standard fitting length of the piston rod is about 80% of the thread diameter. If the fitting length is insufficient due to the use of the lock nut, it is necessary to increase the thread length (dimension A) as shown below.

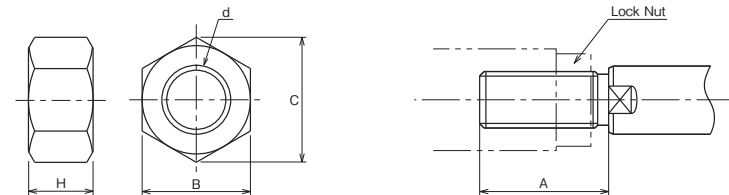

Dimensional Table/Lock nut

Symbol Bore	Part number	B	C	d	H
φ32	LNH-16F-H	22	25.4	M16×1.5	10
φ40	LNH-20F-H	27	31.2	M20×1.5	12
φ50	LNH-24F-H	32	37.0	M24×1.5	14
φ63	LNH-30F-H	41	47.3	M30×1.5	17
φ80	LNH-39F-H	55	63.5	M39×1.5	20
φ100	LNH-48F-H	70	80.8	M48×1.5	26
φ125	LNH-64F-H	90	104.0	M64×2	35
φ140	LNH-72F-H	100	115.0	M72×2	38
φ160	LNH-80F-H	110	127.0	M80×2	43

Dimensional Table/Dimension A

Symbol Bore	A
φ32	40
φ40	45
φ50	50
φ63	60
φ80	80
φ100	95
φ125	125
φ140	140
φ160	155

Change of Rod End Shape

■ You can specify the shape and dimension of the rod end as shown below using the semi-standard symbols and dimension symbols. (No need to specify the dimension symbol if you order a cylinder with the basic dimension. Specify only the semi-standard symbol.)

How to order

Series Model number - X

Semi-standard symbol Dimension symbol (Specify only when the dimension differs from the basic dimension.)
 └─ KM and KP need to be specified as a pair.

Example **A83**

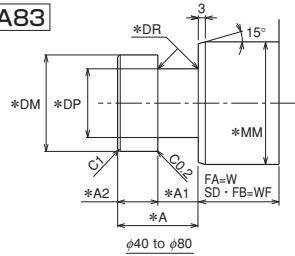

Note) In the case of this shape, specify the change of dimension WF only.

● Bore: $\phi 40$, rod end shape: A83, WF=60
 160ST-1 6SA40N200-X A83
 WF-60

Special Rod End Shapes A00

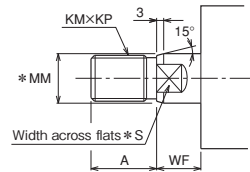

Table of Basic Dimensions (Standard dimensions)

Bore	A	KM	KP	*MM	*S	WF
$\phi 32$	25	16	1.5	$\phi 18$	14	10
$\phi 40$	30	20	1.5	$\phi 22$	19	10
$\phi 50$	35	24	1.5	$\phi 28$	24	11
$\phi 63$	45	30	1.5	$\phi 36$	30	13
$\phi 80$	60	39	1.5	$\phi 45$	41	17
$\phi 100$	75	48	1.5	$\phi 56$	50	26
$\phi 125$	95	64	2	$\phi 70$	65	30
$\phi 140$	110	72	2	$\phi 80$	75	35
$\phi 160$	120	80	2	$\phi 90$	85	40

A51

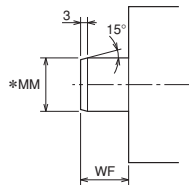
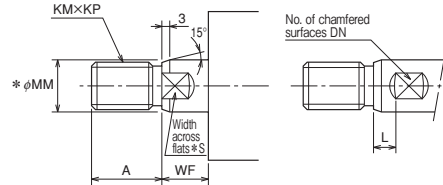

Table of Basic Dimensions

Bore	*MM	WF
$\phi 32$	$\phi 18$	10
$\phi 40$	$\phi 22$	10
$\phi 50$	$\phi 28$	11
$\phi 63$	$\phi 36$	13
$\phi 80$	$\phi 45$	17
$\phi 100$	$\phi 56$	26
$\phi 125$	$\phi 70$	30
$\phi 140$	$\phi 80$	35
$\phi 160$	$\phi 90$	40

- The *-marked dimensions are fixed.
- If it is necessary to change the fixed dimension, consult us.
- The number of chamfered surfaces DN is 2 (standard) or 4 only.

A53



Note) Increase dimension WF by dimension L.

Table of Basic Dimensions

Bore	A	DN	KM	KP	L	*MM	*S	WF
$\phi 32$	25	2	16	1.5	0	$\phi 18$	14	10
$\phi 40$	30	2	20	1.5	0	$\phi 22$	19	10
$\phi 50$	35	2	24	1.5	0	$\phi 28$	24	11
$\phi 63$	45	2	30	1.5	0	$\phi 36$	30	13
$\phi 80$	60	2	39	1.5	0	$\phi 45$	41	17
$\phi 100$	75	2	48	1.5	0	$\phi 56$	50	26
$\phi 125$	95	2	64	2	0	$\phi 70$	65	30
$\phi 140$	110	2	72	2	0	$\phi 80$	75	35
$\phi 160$	120	2	80	2	0	$\phi 90$	85	40

A54

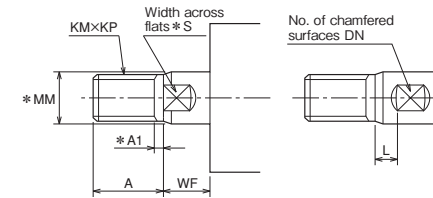

Table of Basic Dimensions

Bore	A	*A1	DN	KM	KP	L	*MM	*S	WF
$\phi 32$	25	4	2	16	1.5	0	$\phi 18$	14	10
$\phi 40$	30	4	2	20	1.5	0	$\phi 22$	19	10
$\phi 50$	35	4	2	24	1.5	0	$\phi 28$	24	11
$\phi 63$	45	4	2	30	1.5	0	$\phi 36$	30	13
$\phi 80$	60	4	2	39	1.5	0	$\phi 45$	41	17
$\phi 100$	75	4	2	48	1.5	0	$\phi 56$	50	26
$\phi 125$	95	5	2	64	2	0	$\phi 70$	65	30
$\phi 140$	110	5	2	72	2	0	$\phi 80$	75	35
$\phi 160$	120	5	2	80	2	0	$\phi 90$	85	40

A81

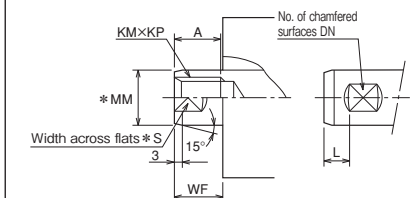
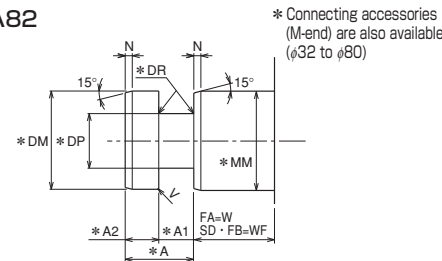

Table of Basic Dimensions

Bore	A	DN	KM	KP	L	*MM	*S	WF
$\phi 32$	15	2	12	1.75	0	$\phi 18$	14	10
$\phi 40$	20	2	16	2	0	$\phi 22$	19	10
$\phi 50$	24	2	20	2.5	0	$\phi 28$	24	11
$\phi 63$	33	2	27	3	0	$\phi 36$	30	13
$\phi 80$	36	2	30	3.5	0	$\phi 45$	41	17
$\phi 100$	45	2	39	4	0	$\phi 56$	50	26
$\phi 125$	58	2	48	5	0	$\phi 70$	65	30

A82



* Connecting accessories (M-end) are also available. ($\phi 32$ to $\phi 80$)

Table of Basic Dimensions

Bore	*A	*A1 ^{+0.5/0.3}	*A2 ^{-0.2/0.3}	*DM	*DP ^{-0.2/0.3}	*DR	*MM	*N	*V	W	WF
$\phi 32$	25	12.5	12.5	$\phi 18$	$\phi 13$	1	$\phi 18$	3	C0.2	30	30
$\phi 40$	25	12.5	12.5	$\phi 22$	$\phi 16$	1.5	$\phi 22$	3	C0.2	35	35
$\phi 50$	25	12.5	12.5	$\phi 28$	$\phi 21$	1.5	$\phi 28$	3	C0.2	35	35
$\phi 63$	30	15	15	$\phi 36$	$\phi 26$	2	$\phi 36$	3	C0.2	40	40
$\phi 80$	30	15	15	$\phi 45$	$\phi 31$	2	$\phi 45$	3	C0.2	45	45
$\phi 100$	40	20	20	$\phi 56$	$\phi 38$	3	$\phi 56$	3	C0.2	55	55
$\phi 125$	50	25	25	$\phi 70$	$\phi 49$	3.5	$\phi 70$	3	R1	60	60
$\phi 140$	50	25	25	$\phi 80$	$\phi 56$	4	$\phi 80$	3	R1	65	65
$\phi 160$	60	30	30	$\phi 90$	$\phi 60$	5	$\phi 90$	6	R1	70	70

- The *-marked dimensions are fixed.
- If it is necessary to change the fixed dimension, consult us.
- The number of chamfered surfaces DN is 2 (standard) or 4 only.

A83

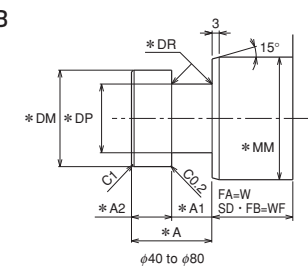
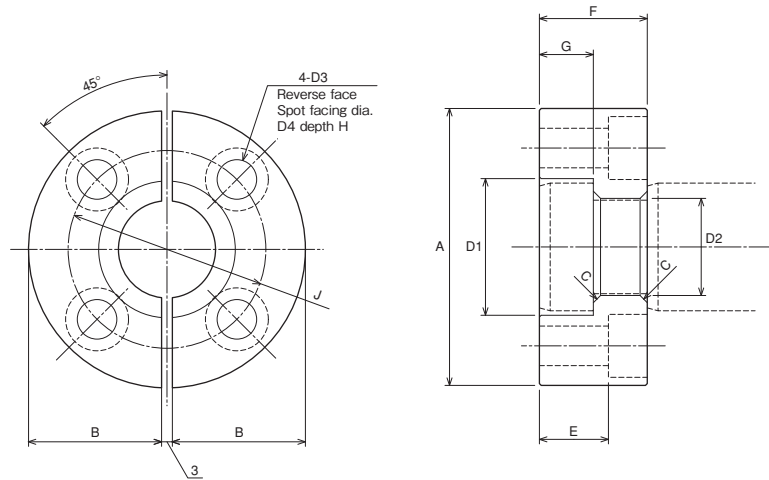

Table of Basic Dimensions

Bore	*A	*A1 ^{+0.5/0.3}	*A2 ^{-0.2/0.3}	*DM	*DP ^{-0.2/0.3}	*DR	*MM	W	WF
$\phi 40$	25	12.5	12.5	$\phi 18$	$\phi 13$	1	$\phi 22$	35	35
$\phi 50$	25	12.5	12.5	$\phi 22$	$\phi 16$	1.5	$\phi 28$	35	35
$\phi 63$	25	12.5	12.5	$\phi 28$	$\phi 21$	1.5	$\phi 36$	40	40
$\phi 80$	30	15	15	$\phi 36$	$\phi 26$	2	$\phi 45$	45	45

Separate flange joint (M-end): Only for rod end shape A82



● Additional order must be made for this item. Specify as RMH-**.

Dimensional Table

Symbol	Part number	A	B	C	D1	D2	D3	D4	E	F	G	H	J
Bore													
φ20	RMH-12	φ44	20.5	0.5	φ13	φ8.5	φ5.5	φ9.5	19.6	25	12.5	5.4	φ29
φ25	RMH-14	φ46	21.5	0.5	φ15	φ10.5	φ5.5	φ9.5	19.6	25	12.5	5.4	φ31
φ32	RMH-18	φ49	23	1	φ19	φ13.5	φ6.6	φ11	18.5	25	12.5	6.5	φ34
φ40	RMH-22	φ57	27	1.5	φ23	φ16.5	φ9	φ14	16.4	25	12.5	8.6	φ40
φ50	RMH-28	φ71	34	1.5	φ29	φ21.5	φ11	φ17.5	14.2	25	12.5	10.8	φ50
φ63	RMH-36	φ77	37	2	φ38	φ27	φ11	φ17.5	19.2	30	15	10.8	φ55
φ80	RMH-45	φ100	48.5	2	φ48	φ33	φ14	φ20	17	30	15	13	φ76